

# Lifting 184 mld Raw Water in Arduous conditions directly from the Gorge of the river Narmada for Indore WSS project since 2012

Site : Backwaters of Maheshwar dam, Julud village - Khargone district, MP.

Almost Impossible Operating conditions (24m of Flooding, minimum 600m away from nearest motorable approach point; heavy & repeated burial under Sand & Silt & yet 24x7x365 operation) proven Ruggedness & yet High Efficiency nature of Aqua's SubCF pumpsets ensured that AQUA was once again chosen to supply large-scale raw water pumps when it was time to augment water supply to Indore city

### AQUA Provided

- High & Sustainable Efficiency pumpsets ensure substantial Power savings.
- Pumpsets installed on portable stands & reliable maintenance free raw water even under challenging circumstances.

### The Situation :

**Indore**, the commercial capital of the state Madhya Pradesh has been also selected as one of the 100 Indian cities to be developed as a smart city under Smart Cities Mission & its demand of drinking water rises day by day. Indore residents were supplied Narmada drinking water only on alternate days and that too for 20-40 minutes. Many colonies in the city and with inclusion of 29 villages into the Municipal limits were still devoid of drinking water supply. In the root cause of these, was the difficult terrain at Jalud intake where raw water had to be tapped from river groge approximately 600m away & almost 24m deep below the nearest motorable approach point.

Due to Loose Sand strata near the intake point even minor rains deposit huge amount of Sand onto the sump (which has its Top at 146.5m – i.e. is well below the HFL).

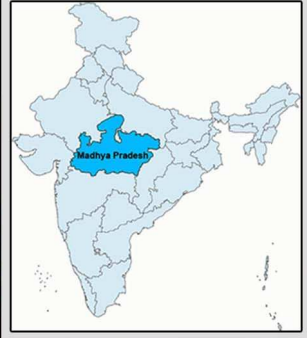

92 MLD 2 Nos. pumps in phase-1 (1W +1S) [ARS 5063 TQ L 415]

Additional 92 MLD 2 Nos. pumps in phase-1 (1W +1S)  
[ARS\_H\_PS\_1st\_BVo\_5064\_M\_L\_0590\_06600\_NJ]

Maheshwar Dam

॥ नमामि देवी नर्मदे ॥  
The River Narmada

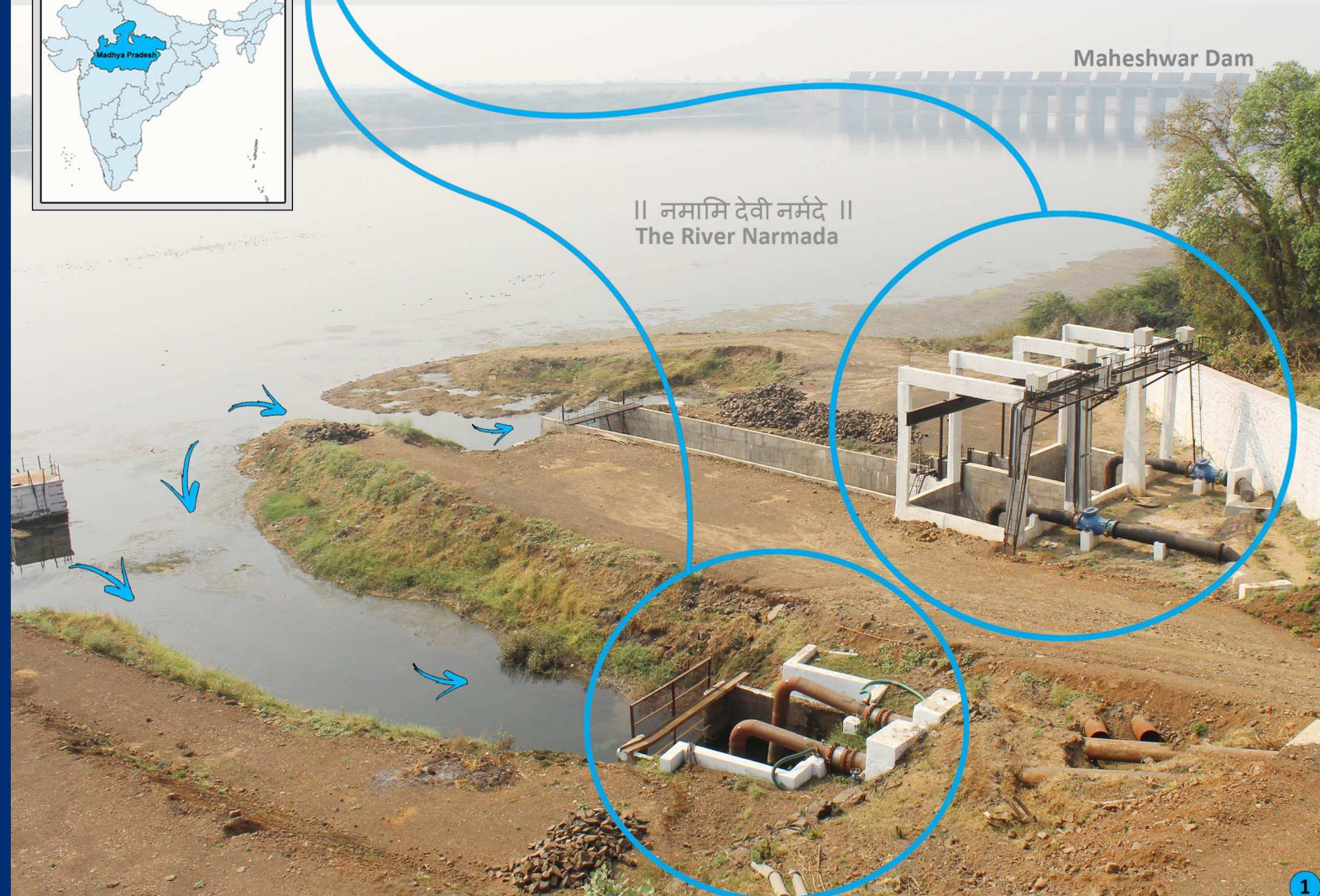



**Model Code** : ARS\_5063\_TQ\_L\_475  
*[Each of 475 hp, 3835 m<sup>3</sup>/hr (92 MLD), 25 m Head - 1W+1S]*

**Model Code** : ARS\_H\_PS\_1st\_BVo\_5064\_M\_L\_0590\_06600\_NJ  
*[Each of 590 hp - 6.6 kV, 3835 m<sup>3</sup>/hr (92 MLD), 30.5 m Head - 1W+1S]*

**Project Name** : Narmada Phase III, Mandleshwar.

**End User** : Indore Municipal Corporation (vide PHE's Project Uday wing)

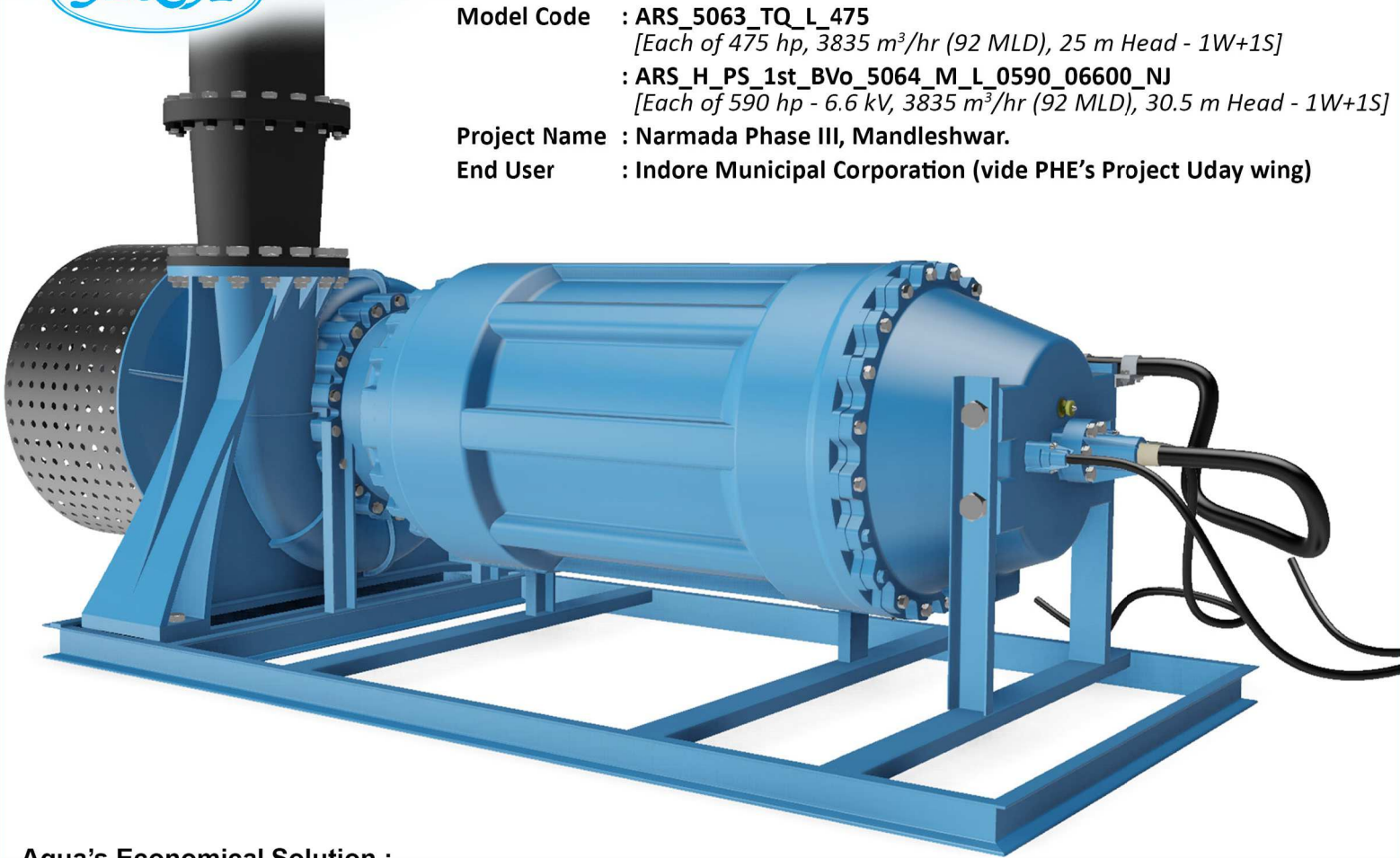

**Aqua's Economical Solution :**

92mld Raw water Submerged Centrifugal pump sets (ARS 5063 TQ L 415, 2 Nos. 1W +1S and ARS H PS 1st BVo 5064 M L 0590 06600 NJ, 2 Nos. 1W +1S) were the best & almost exclusive choice since it could be easily rested at the bottom of the sump. Also being Submerged Centrifugal Pumps they were suitable for working in hostile environment under 24m of flooding & heavy Sand burial where in no other type of pumps were suited for direct installation without any Pumping House.



Both the Sumps are well bellow the HFL & get periodically buried under silt



Vide AQUA's SubCF Pumpset

Schematic diagram :

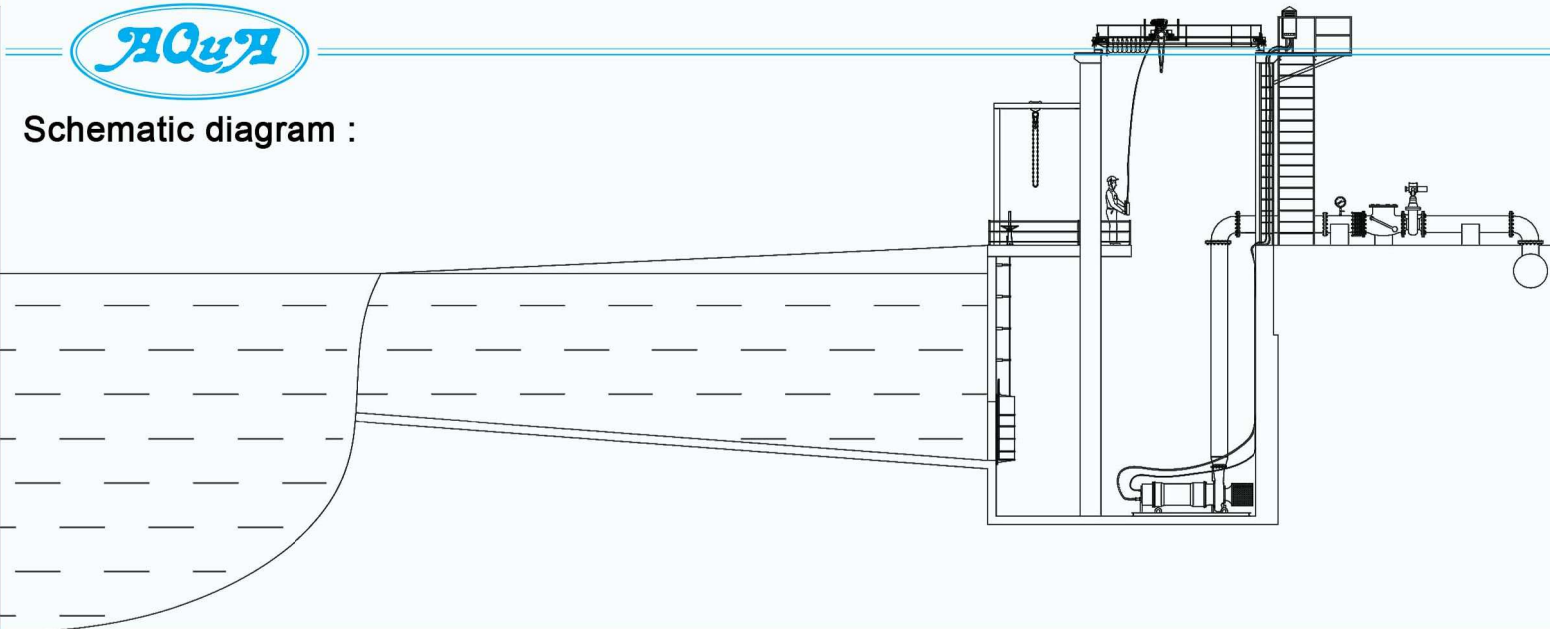

Schematic Hydraulic flow Diagram :

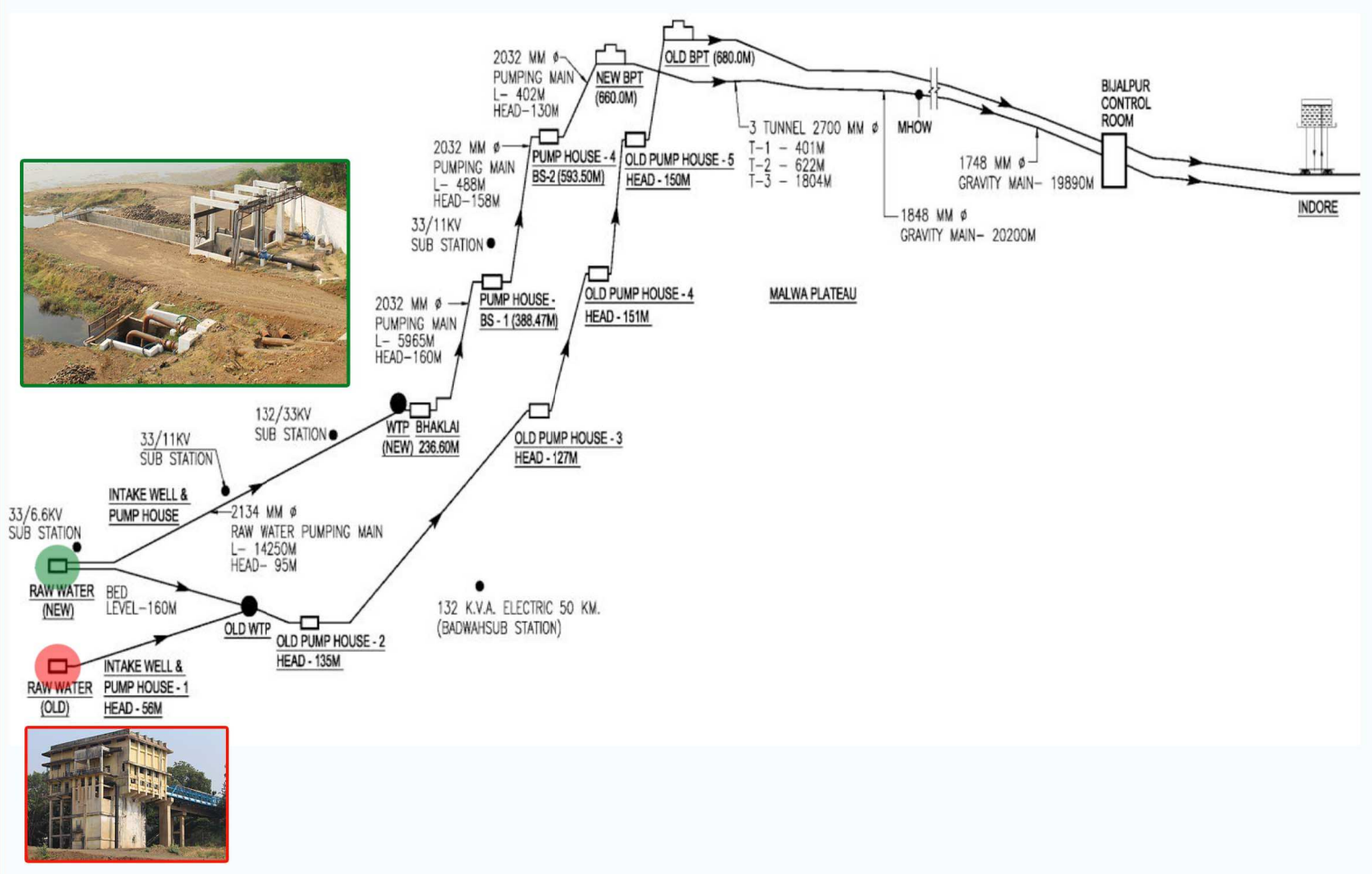

During flood; the Pump & Pumpsets are often buried under silt but the robust pumpsets are working unhindered.



**शहर के 70 फीसदी इलाकों में अब रोज मिलेगा पानी**

180 एमएलडी पानी बढ़ाने के लिए नर्मदा तट दो पंप स्थापित

शहर के 70 फीसदी इलाकों में अब रोज मिलेगा पानी

शहर के 70 फीसदी इलाकों में अब रोज मिलेगा पानी



**INDORE MUNICIPAL CORPORATION**

Executive Engineer, Maint. Dn. No.1 (IMC)  
Mandleshwar- 451221, Distt: Khargone (M.P.)  
E-Mail: [eephedmdi@rediffmail.com](mailto:eephedmdi@rediffmail.com)

No. 101 EE/AS/MDI/2017-18/ Mandleshwar

Date. 18.01.2018

**TO WHOM SO EVER IT MAY CONCERN**

It is certified that the work " Design, Manufacturing, Supply, Installaation, Testing & Commissioning of 92 mld Submerged Centrifugal Pumps Sets 2 nos. with Electrical Equipment and other allied works has been awarded to M/s Aqua Machineris Pvt. Ltd., Plot no. 3821, GIDC Phase- IV, Vatva, Ahmedabad vide letter no. 4047 dated 05.09.2012. The above pumps of Capacity 3835m<sup>3</sup>/hr., Head- 25m., rated 355KW, 415V, 50Hz. model ARS 5063 TQ L 475 are installed in open Sump near Intake well under Indore Water Supply Scheme.

2 nos., AQUA make Submerged Centrifugal Pumps Sets of Capacity 3835m<sup>3</sup>/hr., Head- 30.5m., rated 440KW, 6.6 KV, 50Hz are also installed & commissioned in the month August 2017 by M/s. Asiatic Traders, Indore vide letter no. 194 dated 23.01.2017.

Above Pumps are working satisfactorily.

Above certificate is issued for tender purpose only.

*(Signature)*  
18/01/2018  
**(S.K. Kuril)**  
Executive Engineer  
Maint. Dn. No.1 (IMC)  
Mandleshwar.